

# 10FAFL-1-13A

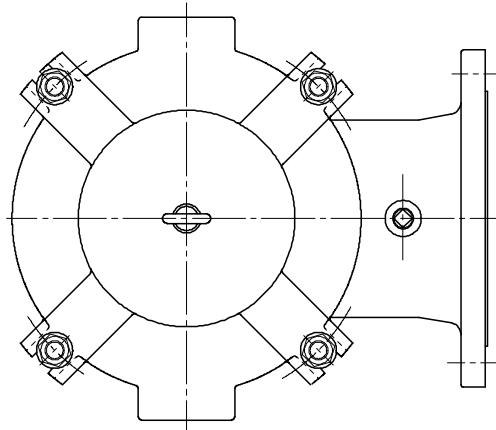

SIZE	d	L1	L2	FLANGED								W1	W2	W3	H	WEIGHT kg	Q'TY
				D	C	g	f	t	N	h							
125	5	125	215	280	250	210	182	2	20	8	23	R1/2	R3/8	R3/8	431	50	
150	6	150	235	295	280	240	212	2	22	8	23	R1/2	R3/8	R3/8	458	70	
200	8	200	280	350	330	290	262	2	22	12	23	R3/4	R3/8	R3/8	541	100	

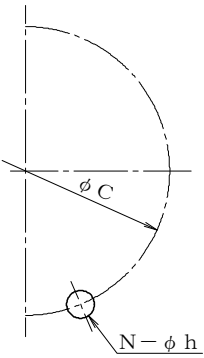
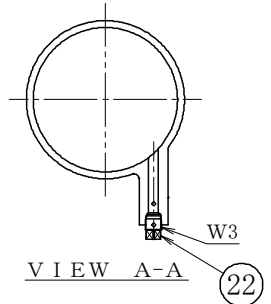
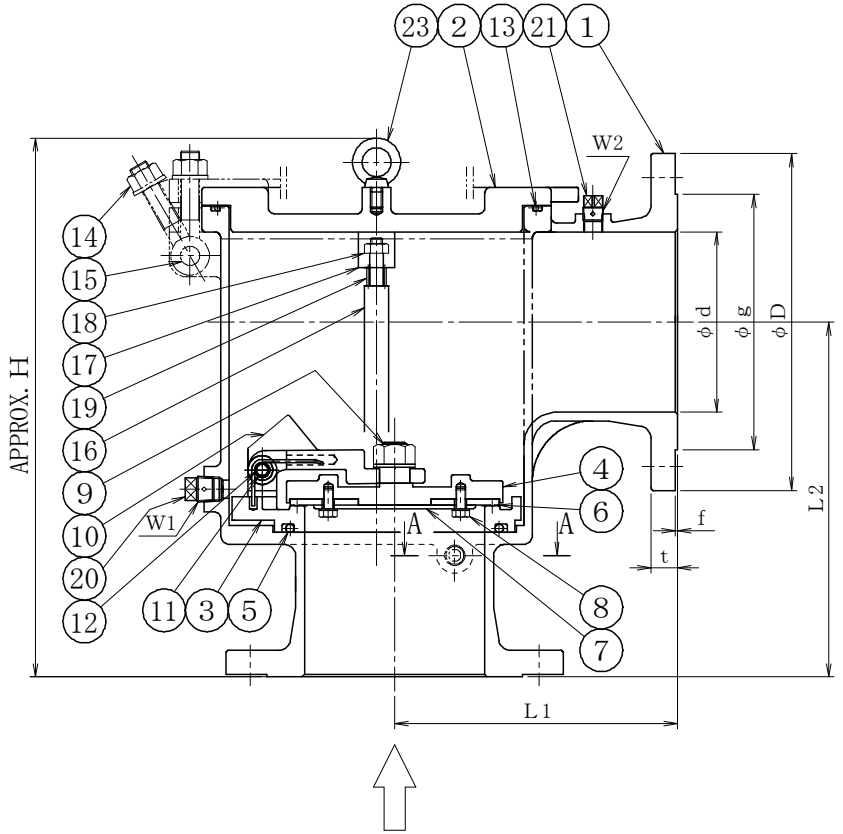

23	EYE BOLT	SUS 304	1	
22	PLUG	SUS 304	1	
21	PLUG	SUS 304	1	
20	PLUG	SUS 304	1	
19	SPRING	SUS 304	2	
18	U-NUT	SUS 304	2	
17	PLATE	SCS 13A	1	
16	POLE	SUS 304	2	
15	BOLT/U-NUT	SUS 304	SET	
14	SWING BOLT/NUT/WASHER	SUS 304	SET	
13	O-RING	EPDM	1	
12	SPRING	SUS 304	1	
11	PIN/E-RING	SUS 304	1	
10	HINGE	SCS 13A	1	
9	U-NUT/WASHER	SUS 304	SET	
8	BOLT/SPRING WASHER	SUS 304	SET	
7	DISC PLATE	SUS 304	1	
6	SEAT PACKING	EPDM	1	
5	O-RING	EPDM	1	
4	DISC	SCS 13A	1	
3	SEAT	SCS 13A	1	
2	COVER	SCS 13A	1	
1	BODY	SCS 13A	1	
No	NAME OF PART	MATERIAL	Q.T.Y	REMARKS

NAME 10K FLANGED  
ANGLE TYPE FOOT VALVE

FLUID	DESIGN PRESSURE	DESIGN TEMPERATURE	TEST PRESSURE	BODY	
				(HYD)	(AIR)
	1.0 MPaG	60 °C		1.5 MPaG	— MPaG
				SEAT	
				(HYD)	(AIR)
				0.2 MPaG	— MPaG
				(HYD)	(AIR)
				— MPaG	— MPaG

DRAWING No		MODEL No 10FAFL-1-13A		
DATE	A. P	C. K	D. S	D. W
SEP. 8. 2020	TAKAHASHI	TAKAHASHI	MORITA	MORITA

**MM** THREE-M INDUSTRY CO., LTD.

No	DESCRIPTION	DATE	A. P	C. K	D. W
REVISIONS					