

10FAFL-1-13A

SIZE	d	L1	L2	FLANGED								W1	W2	W3	H	WEIGHT (kg)	Q'TY
				D	C	g	f	t	N	h							
40	1 1/2	40	120	210	140	105	81	2	16	4	19	R3/8	R3/8	R3/8	295	13	
50	2	50	120	210	155	120	96	2	16	4	19	R3/8	R3/8	R3/8	300	15	
65	2 1/2	65	130	230	175	140	116	2	18	4	19	R1/2	R3/8	R3/8	325	20	
80	3	80	140	240	185	150	126	2	18	8	19	R1/2	R3/8	R3/8	355	26	
100	4	100	150	240	210	175	151	2	18	8	19	R1/2	R3/8	R3/8	370	30	

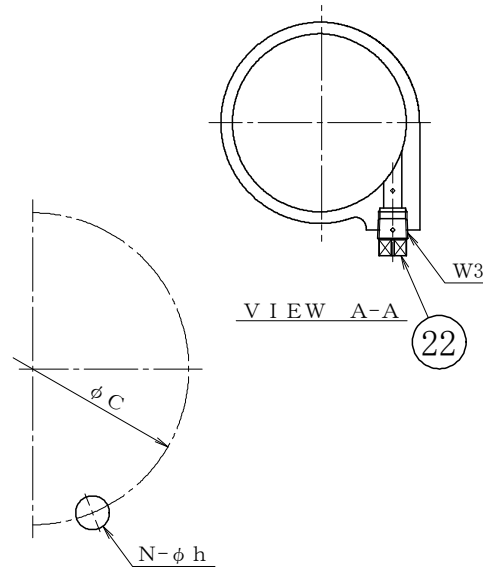
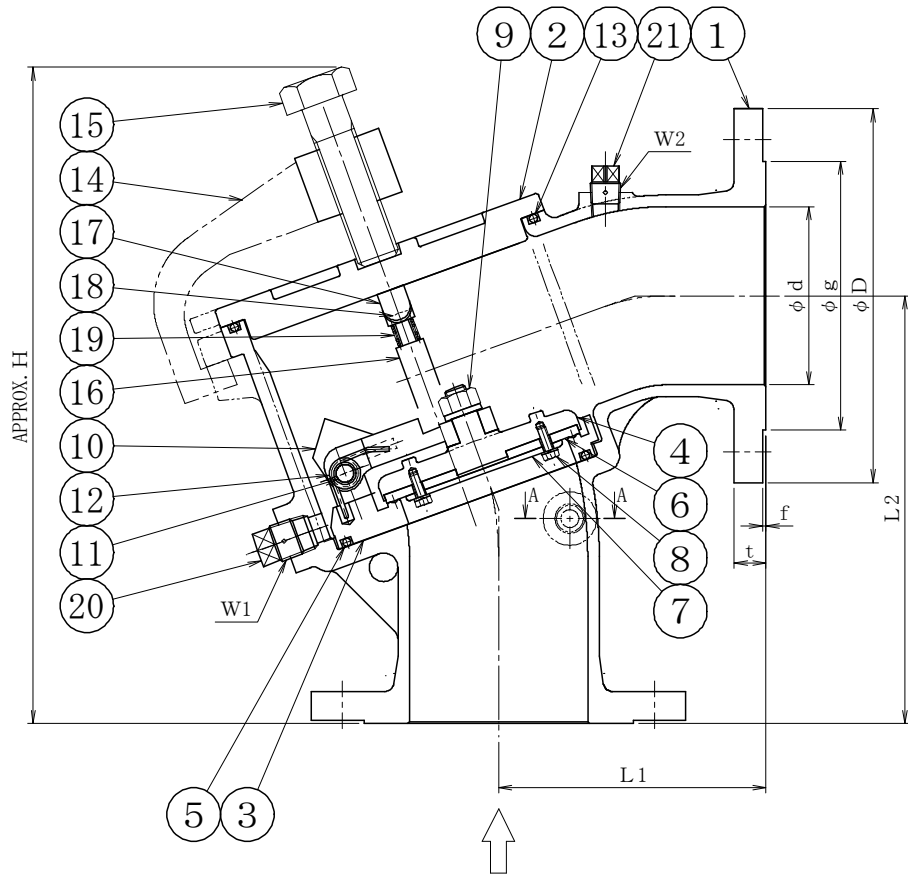

No	NAME OF PART	MATERIAL	Q.T.Y	REMARKS
22	PLUG	SUS304	1	
21	PLUG	SUS304	1	
20	PLUG	SUS304	1	
19	SPRING	SUS304	2	
18	U-NUT	SUS304	2	
17	PLATE	SCS13A	1	
16	POLE	SUS304	2	
15	BOLT	SUS304	1	
14	SET YOKE	SCS13A	1	
13	O-RING	EPDM	1	
12	SPRING	SUS304	1	
11	PIN/E-RING	SUS304	1	
10	HINGE	SCS13A	1	
9	U-NUT/WASHER	SUS304	SET	
8	BOLT/SPRING WASHER	SUS304	SET	
7	DISC PLATE	SUS304	1	
6	SEAT PACKING	EPDM	1	
5	O-RING	EPDM	1	
4	DISC	SCS13A	1	
3	SEAT	SCS13A	1	
2	COVER	SCS13A	1	
1	BODY	SCS13A	1	

NAME 10K FLANGED ECOFOOT® (ANGLE TYPE FOOT VALVE)				
FLUID		TEST PRESSURE	BODY	(HYD) 1.5 MPaG (AIR) — MPaG
DESIGN PRESSURE	1.0 MPaG		SEAT	(HYD) 0.2 MPaG (AIR) — MPaG
DESIGN TEMPERATURE	60 °C			(HYD) — MPaG (AIR) — MPaG
DRAWING No			MODEL No 10FAFL-1-13A	
DATE	A. P	C. K	D. S	D. W
SEP. 01. 2018	KAIMOTO	KAIMOTO	MORITA	TAKAHASHI

No	DESCRIPTION	DATE	A. P	C. K	D. W
REVISIONS					