

10FF-H-13

SIZE	d	H	FLANGED								B	X	H1	H2	E	F	WEIGHT Kg
			D	C	g	f	t	N	h								
200	8	200	397	330	290	262	2	20	12	23	352	350	248	149	168	12	36
250	10	250	505	400	355	324	2	22	12	25	436	440	327	178	209	12	63
300	12	300	630	445	400	368	3	22	16	25	515	550	383	247	279	14	110

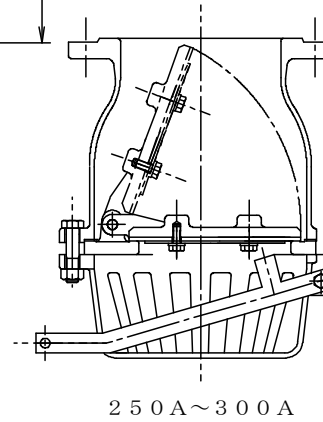
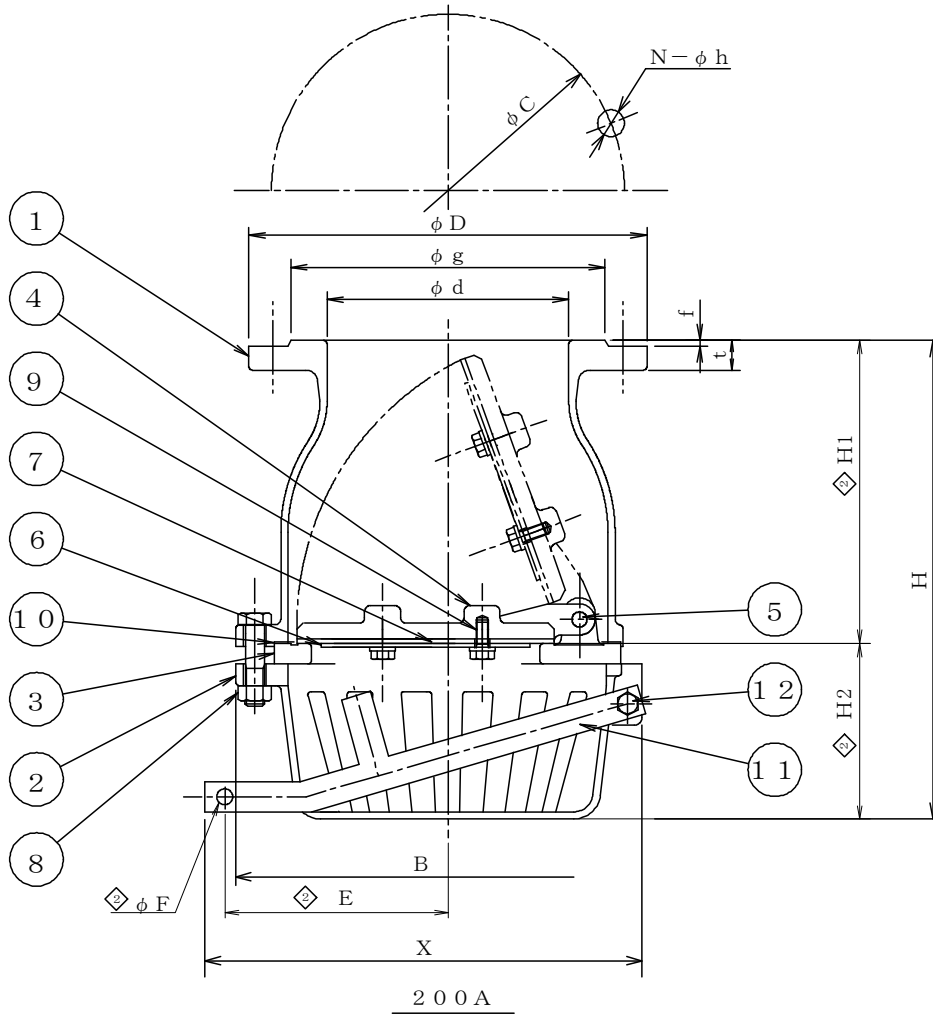

12	BOLT NUT	SUS304	1SET	
11	LEVER	SUS304	1	
10	GASKET	V#7010	1	
9	BOLT WASHER	SUS304	SET	
8	BOLT NUT	SUS304	SET	
7	SEAT PACKING	Si	1	
6	DISC PLATE	SUS304	1	
5	PIN	SUS304	1	
4	DISC	SCS 13	1	
3	SEAT	SCS 13	1	
2	STRAINER	SCS 13	1	
1	BODY	SCS 13	1	
No	NAME OF PART	MATERIAL	Q.T.Y	REMARKS

NAME 10K				
FLANGED FOOT VALVE				
FLUID		TEST PRESSURE	BODY	(HYD) 0.2 MPaG (AIR) MPaG
DESIGN PRESSURE	MPaG		SEAT	FILLING WATER TEST
DESIGN TEMPERATURE	60~80 °C			(HYD) MPaG (AIR) MPaG
DRAWING No			MODEL No 10FF-H-13	
DATE	A. P	C. K	D. S	D. W
SEP. 16, 2005	MORITA	MORITA	MORITA	MORITA

No	DESCRIPTION	DATE	A. P	C. K	D. W
①					
②					
③	Dimensioning	JAN. 28, '20	TAKAHASHI	TAKAHASHI	MORITA
④	change lever	2015. 3. 19	MORITA	MORITA	MORITA

REVISIONS