

10FF-H-13

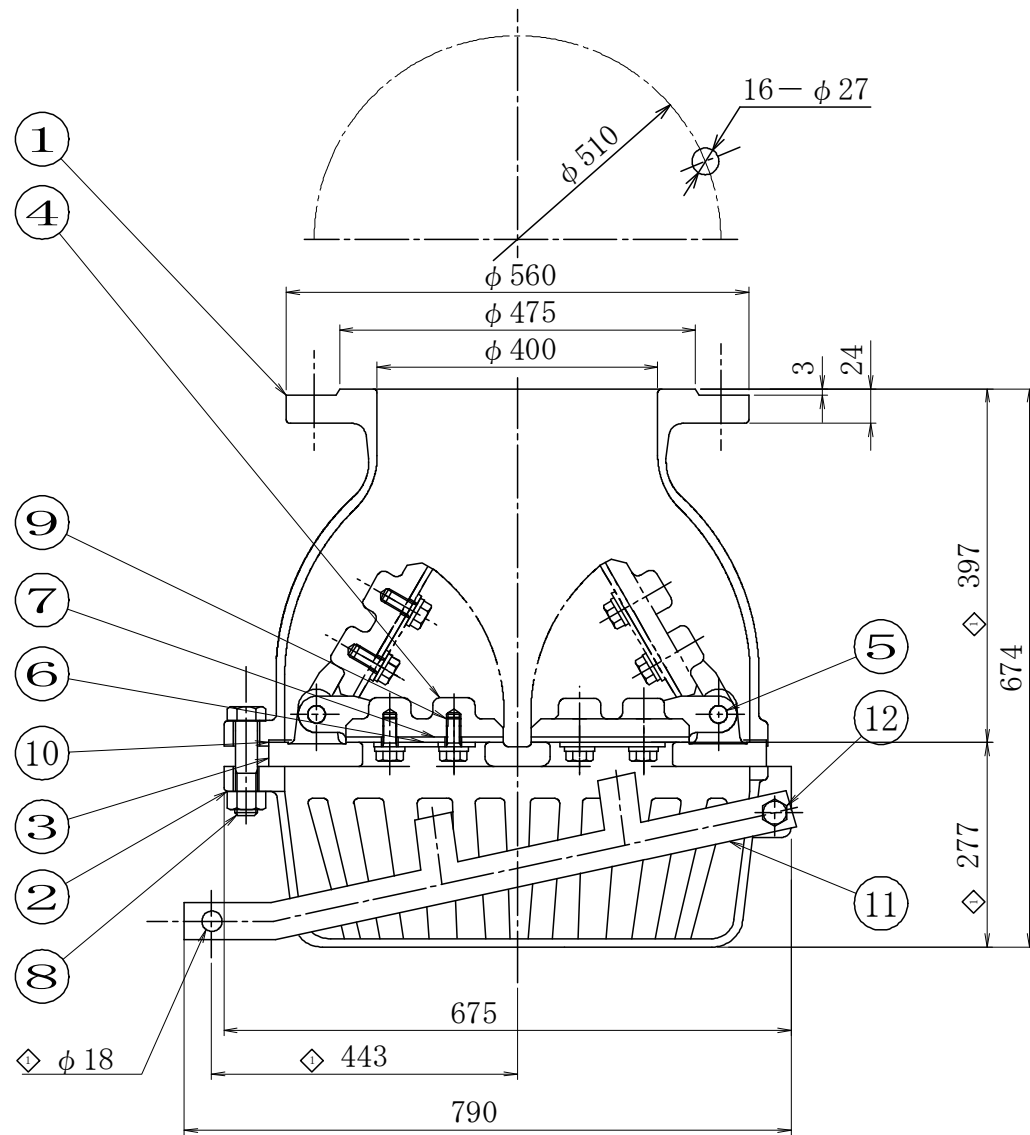

| 12 | BOLT NUT | SUS304 | 1SET | |
|----|--------------|----------|-------|---------|
| 11 | LEVER | SUS304 | 1 | |
| 10 | GASKET | V#7010 | 1 | |
| 9 | BOLT WASHER | SUS304 | SET | |
| 8 | BOLT NUT | SUS304 | SET | |
| 7 | SEAT PACKING | Si | 2 | |
| 6 | DISC PLATE | SUS304 | 2 | |
| 5 | PIN | SUS304 | 2 | |
| 4 | DISC | SCS 13 | 2 | |
| 3 | SEAT | SCS 13 | 1 | |
| 2 | STRAINER | SCS 13 | 1 | |
| 1 | BODY | SCS 13 | 1 | |
| No | NAME OF PART | MATERIAL | Q.T.Y | REMARKS |

NAME 10K-400
FLANGED FOOT VALVE

| | | | | |
|--------------------|----------|---------------|------|------------------------------|
| FLUID | | TEST PRESSURE | BODY | (HYD) 0.2 MPaG (AIR) MPaG |
| DESIGN PRESSURE | MPaG | | SEAT | FILLING WATER TEST |
| DESIGN TEMPERATURE | 60~80 °C | | | (HYD) MPaG (AIR) MPaG |

DRAWING No _____ MODEL No 10FF-H-13

| | | | | |
|---------------|--------|--------|--------|--------|
| DATE | A. P | C. K | D. S | D. W |
| SEP. 16, 2005 | MORITA | MORITA | MORITA | MORITA |

MM THREE-M INDUSTRY CO., LTD.

| No | DESCRIPTION | DATE | A. P | C. K | D. W |
|-----------|--------------|--------------|-----------|-----------|--------|
| 3 | | | | | |
| 2 | | | | | |
| 1 | Dimensioning | JAN. 28, '20 | TAKAHASHI | TAKAHASHI | MORITA |
| REVISIONS | | | | | |