

10FF-H-13

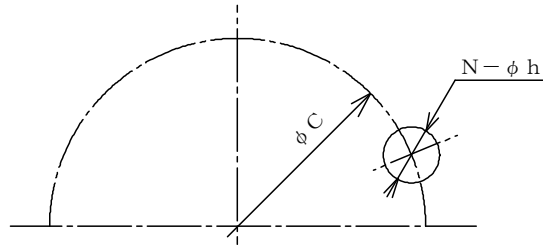

SIZE	d	H	FLANGED								B	X	H1	H2	E	F	WEIGHT Kg
			D	C	g	f	t	N	h								
40	1 1/2	40	155	140	105	81	2	14	4	19	140	160	91	64	85	7	4
50	2	50	155	155	120	96	2	14	4	19	140	160	91	64	85	7	4
65	2 1/2	65	175	175	140	116	2	14	4	19	158	175	104	71	99	7	5
80	3	80	195	185	150	126	2	14	8	19	168	200	118	77	107	7	6
100	4	100	255	210	175	151	2	16	8	19	232	240	157	98	110	7	13
125	5	125	285	250	210	182	2	18	8	23	255	260	174	111	135	9	16
150	6	150	335	280	240	212	2	18	8	23	278	320	206	129	171	9	22.5

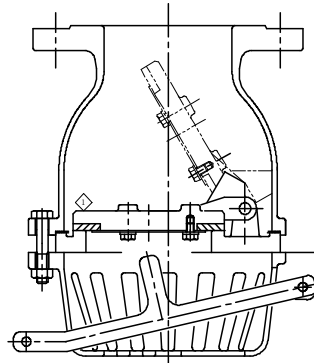
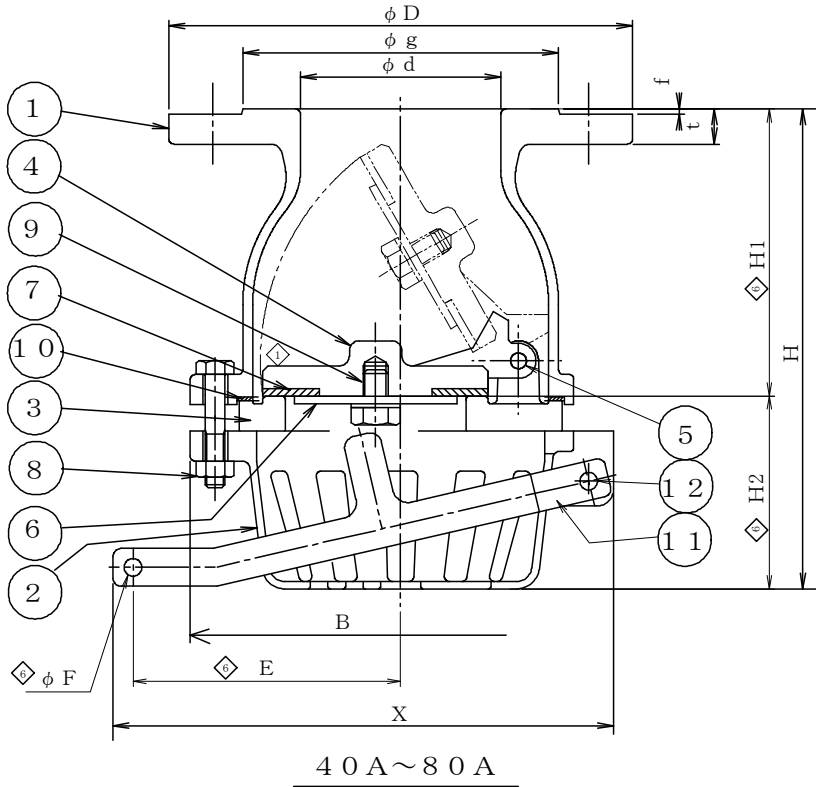

100A

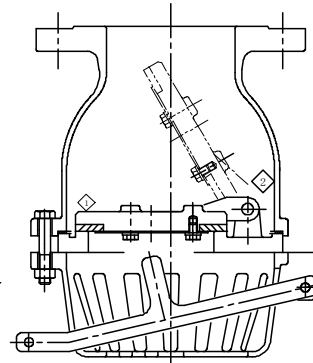

125A~150A

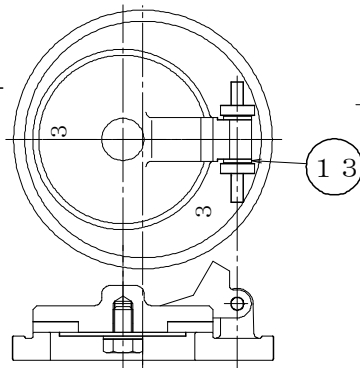

40A~80A

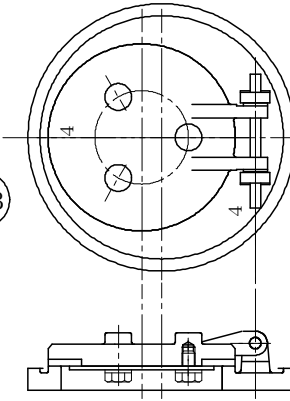

100A~150A

No	NAME OF PART	MATERIAL	Q.T.Y	REMARKS
13	WASHER	SUS304	2	◇
12	BOLT NUT	SUS304	1SET	
11	LEVER	SCS13	1	
10	GASKET	V#7010	1	
9	BOLT WASHER	SUS304	SET	
8	BOLT NUT	SUS304	SET	
7	SEAT PACKING	Si	1	
6	DISC PLATE	SUS304	1	
5	PIN	SUS303	1	
4	DISC	SCS13	1	
3	SEAT	SCS13	1	
2	STRAINER	SCS13	1	
1	BODY	SCS13	1	

NAME 10K				
FLANGED FOOT VALVE				
FLUID		TEST PRESSURE	BODY	(HYD) 0.2 MPaG (AIR) MPaG
DESIGN PRESSURE	MPaG		SEAT	FILLING WATER TEST
DESIGN TEMPERATURE	60~80 °C			(HYD) MPaG (AIR) MPaG
DRAWING No			MODEL No 10FF-H-13	
DATE	A. P	C. K	D. S	D. W
SEP. 16, 2005	MORITA	MORITA	MORITA	MORITA

No	DESCRIPTION	DATE	A. P	C. K	D. W
◇	Dimensioning	JAN. 28, '20	TAKAHASHI	TAKAHASHI	MORITA
REVISIONS					