

10FF-H-13

SIZE	d	H	FLANGED								B	X	H1	H2	E	F	WEIGHT Kg
			D	C	g	f	t	N	h								
450	18	450	790	620	565	530	3	30	20	27	875	928	435	355	448	23	540
500	20	500	810	675	620	585	3	30	20	27	875	928	455	355	448	23	550
550	22	540	860	745	680	640	3	32	20	33	955	1075	468	392	544	23	
600	24	600	880	795	730	690	3	32	24	33	955	1075	488	392	544	23	

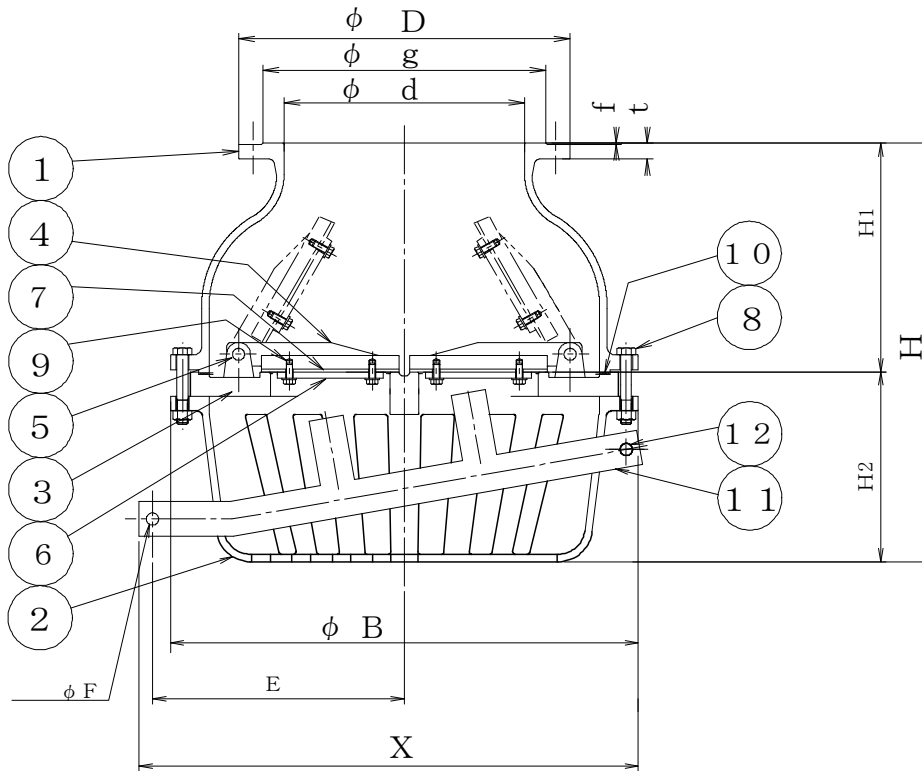
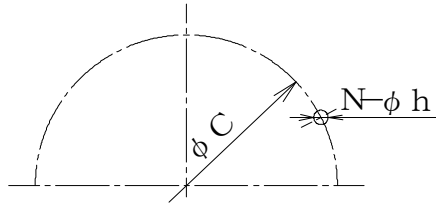

No	NAME OF PART	MATERIAL	Q.T.Y	REMARKS
12	BOLT NUT	SUS304	SET	
11	LEVER	SUS304	1	
10	GASKET	V#7010	1	
9	BOLT WASHER	SUS304	SET	
8	BOLT NUT	SUS304	SET	
7	SEAT PACKING	Si	2	
6	DISC PLATE	SUS304	2	
5	PIN	SUS304	2	
4	DISC	SCS 13	2	
3	SEAT	SCS 13	1	
2	STRAINER	SCS 13	1	
1	BODY	SCS 13	1	

NAME 10K
FLANGED FOOT VALVE

FLUID		TEST PRESSURE	BODY	(HYD) 0.2 MPaG (AIR) MPaG
DESIGN PRESSURE	MPaG		SEAT	FILLING WATER TEST
DESIGN TEMPERATURE	60~80 °C			(HYD) MPaG (AIR) MPaG

DRAWING No _____ MODEL No 10FF-H-13

DATE	A. P	C. K	D. S	D. W
JAN. 29, 2020	TAKAHASHI	TAKAHASHI	MORITA	MORITA

No	DESCRIPTION	DATE	A. P	C. K	D. W

REVISIONS