

10FF-S-13

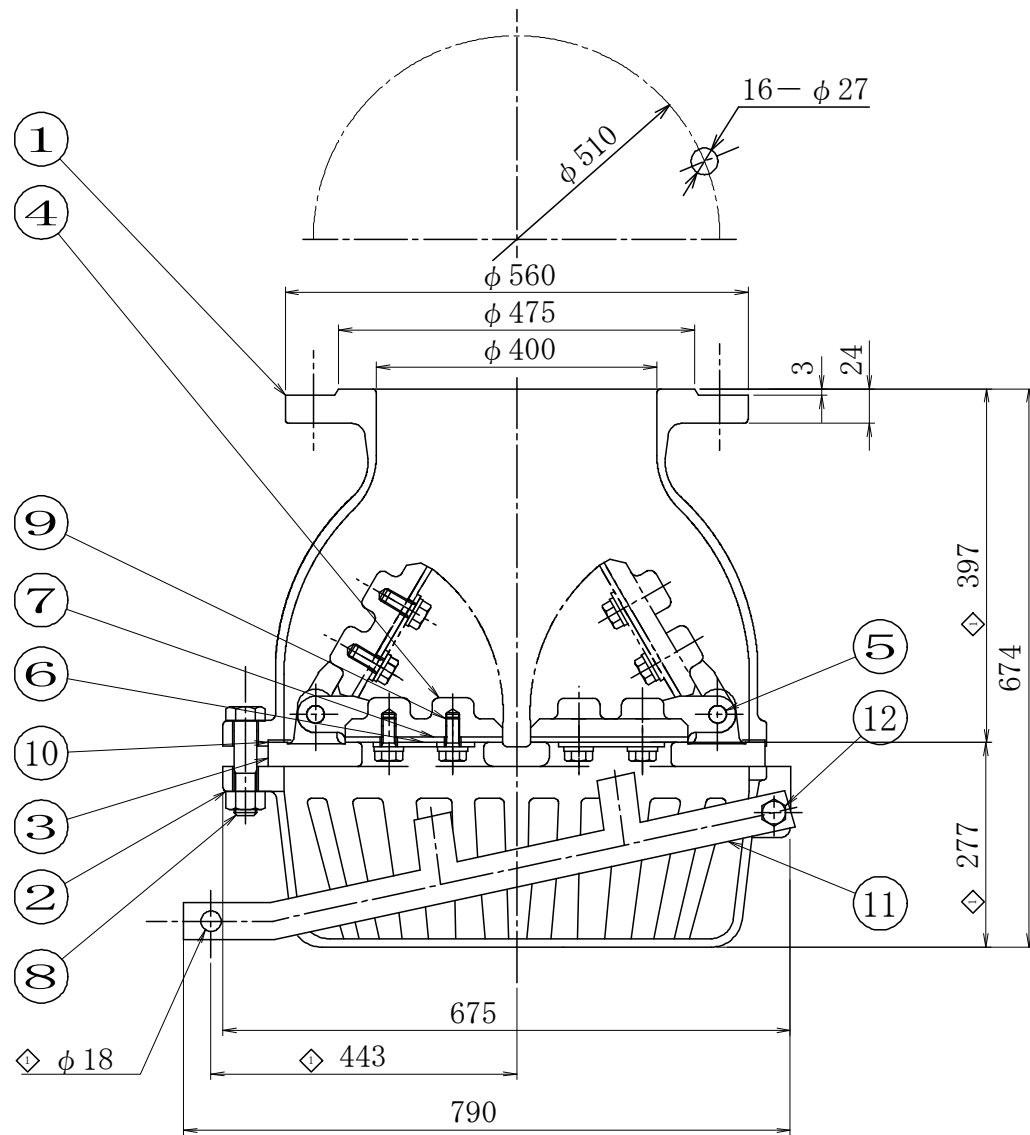

12	BOLT NUT	SUS304	1SET	
11	LEVER	SUS304	1	
10	GASKET	V#7010	1	
9	BOLT WASHER	SUS304	SET	
8	BOLT NUT	SUS304	SET	
7	SEAT PACKING	FPM	2	
6	DISC PLATE	SUS304	2	
5	PIN	SUS304	2	
4	DISC	SCS 13	2	
3	SEAT	SCS 13	1	
2	STRAINER	SCS 13	1	
1	BODY	SCS 13	1	

No	NAME OF PART	MATERIAL	QTY	REMARKS
----	--------------	----------	-----	---------

NAME 10K-400
 FLANGED FOOT VALVE

FLUID		TEST PRESSURE	BODY	(HYD) 0.2 MPaG (AIR) MPaG
DESIGN PRESSURE	MPaG		SEAT	FILLING WATER TEST
DESIGN TEMPERATURE	100 °C			(HYD) MPaG (AIR) MPaG

DRAWING No _____ MODEL No 10FF-S-13

DATE	A. P	C. K	D. S	D. W
SEP. 24, 2005	MORITA	MORITA	MORITA	MORITA

No	DESCRIPTION	DATE	A. P	C. K	D. W
3					
2					
1	Dimensioning	JAN. 29, '20	TAKAHASHI	TAKAHASHI	MORITA

REVISIONS