

| SIZE | d | L | FLANGED | | | | | | | | H | E | F | T | WEIGHT | |
|------|-------|----|---------|-----|-----|----|---|----|---|----|-----|----|----|----|--------|--|
| | | | D | C | g | f | t | N | h | kg | | | | | Q'ty | |
| 10 | 3/8 | 15 | 130 | 90 | 65 | 46 | 1 | 12 | 4 | 15 | 72 | 40 | 50 | 6 | 2.6 | |
| 15 | 1/2 | 15 | 130 | 95 | 70 | 51 | 1 | 12 | 4 | 15 | 72 | 40 | 50 | 6 | 2.6 | |
| 20 | 3/4 | 20 | 130 | 100 | 75 | 56 | 1 | 14 | 4 | 15 | 72 | 40 | 50 | 6 | 3.0 | |
| 25 | 1 | 25 | 150 | 125 | 90 | 67 | 1 | 14 | 4 | 19 | 88 | 50 | 65 | 8 | 4.7 | |
| 32 | 1 1/4 | 32 | 170 | 135 | 100 | 76 | 2 | 16 | 4 | 19 | 116 | 65 | 80 | 10 | 6.0 | |
| 40 | 1 1/2 | 40 | 170 | 140 | 105 | 81 | 2 | 16 | 4 | 19 | 116 | 65 | 80 | 10 | 6.2 | |
| 50 | 2 | 50 | 200 | 155 | 120 | 96 | 2 | 16 | 4 | 19 | 135 | 80 | 95 | 12 | 8.0 | |

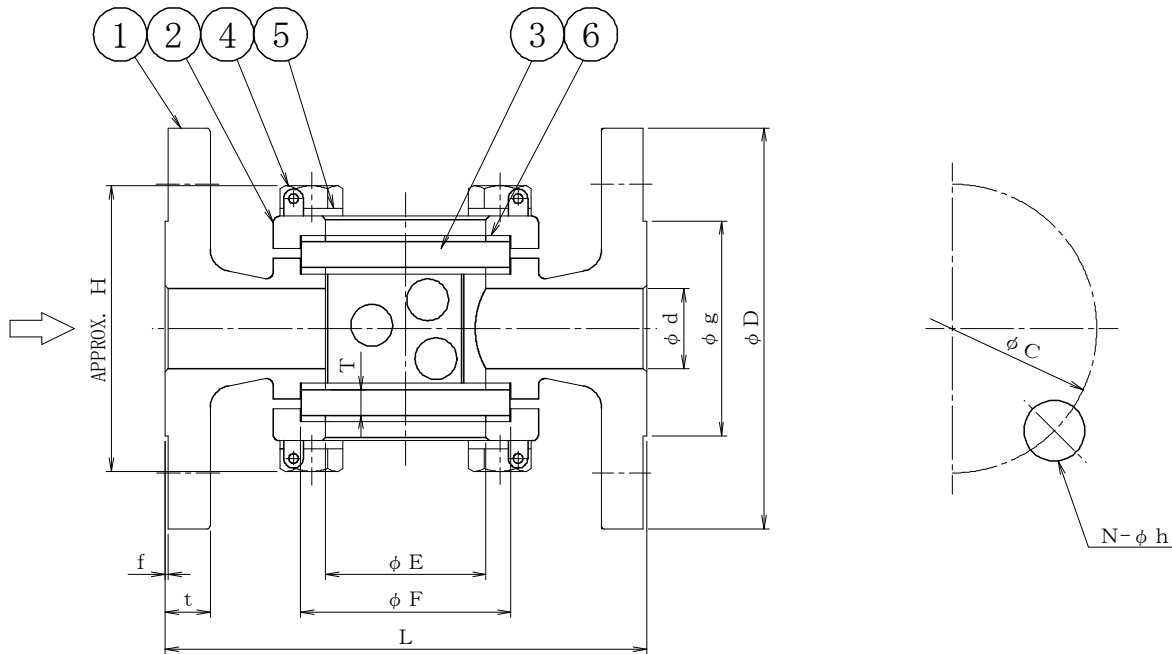

| | | | | |
|----|--------------|----------------|-------|---------|
| 8 | SCREEN | SUS304 | 1 | |
| 7 | BALL | PP ACRYL | SET | |
| 6 | GASKET | T#9007-G20 | 4 | |
| 5 | WASHER | SUS304 | 8 | |
| 4 | BOLT | SUS304 | 8 | |
| 3 | GLASS | TEMPERED GLASS | 2 | |
| 2 | COVER | SCS13A | 2 | |
| 1 | BODY | SCS13A | 1 | |
| No | NAME OF PART | MATERIAL | Q.T.Y | REMARKS |

NAME 10K BALL TYPE
FLANGED SIGHT GLASS

| | | | | |
|--------------------|----------|---------------|------|--------------------------------|
| FLUID | | TEST PRESSURE | BODY | (HYD) 1.5 MPaG (AIR) — MPaG |
| DESIGN PRESSURE | 1.0 MPaG | | SEAT | (HYD) — MPaG (AIR) — MPaG |
| DESIGN TEMPERATURE | 85 °C | | | (HYD) MPaG (AIR) MPaG |

DRAWING No _____ MODEL No 10FGL-2-13A

| | | | | |
|---------------|-----------|-----------|--------|-------|
| DATE | A. P | C. K | D. S | D. W |
| APR. 17, 2023 | TAKAHASHI | TAKAHASHI | MORITA | HORIE |

MM THREE-M INDUSTRY CO., LTD.

| No | DESCRIPTION | DATE | A. P | C. K | D. W |
|-----------|-------------|------|------|------|------|
| REVISIONS | | | | | |