

SIZE	d	L	FLANGED								H	E	F	T	WEIGHT	
			D	C	g	f	t	N	h	kg					Q'ty	
10	3/8	10.0	130	90	65	46	1	12	4	15	72	40	50	6	2.6	
15	1/2	10.0	130	95	70	51	1	12	4	15	72	40	50	6	2.6	
20	3/4	15.0	130	100	75	56	1	14	4	15	72	40	50	6	3.0	
25	1	20.0	150	125	90	67	1	14	4	19	88	50	65	8	4.7	
32	1 1/4	26.0	170	135	100	76	2	16	4	19	116	65	80	10	6.0	
40	1 1/2	34.0	170	140	105	81	2	16	4	19	116	65	80	10	6.2	
50	2	44.6	200	155	120	96	2	16	4	19	135	80	95	12	8.0	

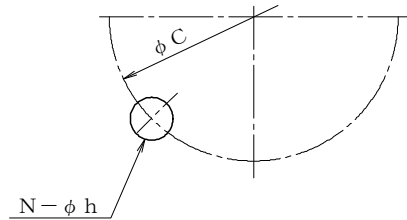
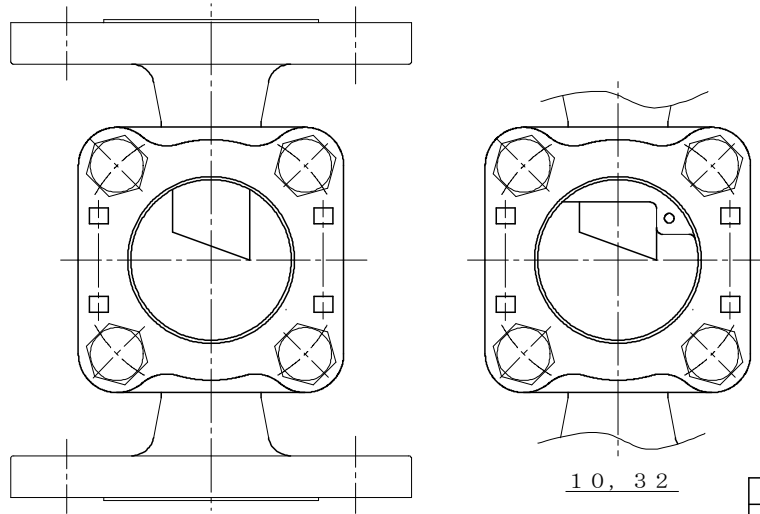
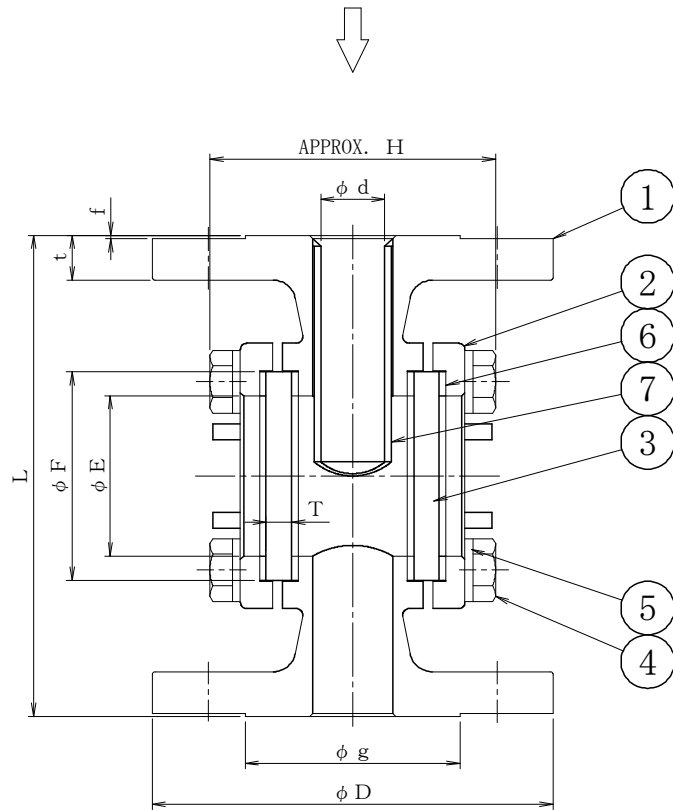

7	NOZZLE	SUS304	1	
6	GASKET	T#9007-G20	4	
5	WASHER	SUS304	8	
4	BOLT	SUS304	8	
3	GLASS	TEMPERED GLASS	2	
2	COVER	SCS13A	2	
1	BODY	SCS13A	1	

No	NAME OF PART	MATERIAL	Q.T.Y	REMARKS
----	--------------	----------	-------	---------

NAME 10K NOZZLE TYPE
FLANGED SIGHT GLASS

FLUID	DESIGN PRESSURE	DESIGN TEMPERATURE	TEST PRESSURE	BODY	
				(HYD)	(AIR)
	1.0 MPaG	150 °C		1.5 MPaG	— MPaG
				SEAT	
				(HYD)	(AIR)
				— MPaG	— MPaG

DRAWING No _____ MODEL No 10FGL-4-13A

DATE	A. P	C. K	D. S	D. W
APR. 17. 2023	TAKAHASHI	TAKAHASHI	MORITA	HORIE



THREE-M INDUSTRY CO., LTD.

No	DESCRIPTION	DATE	A. P	C. K	D. W
REVISIONS					