

SIZE	d	L	FLANGED								H	E	F	T	WEIGHT	
			D	C	g	f	t	N	h	kg					Q'ty	
65	2 1/2	59.5	270	175	140	116	2	18	4	19	184	120	140	19	18.5	
80	3	70.3	270	185	150	126	2	18	8	19	184	120	140	19	19	
100	4	95.0	320	210	175	151	2	18	8	19	228	155	180	22	30	

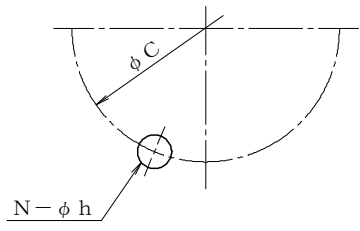
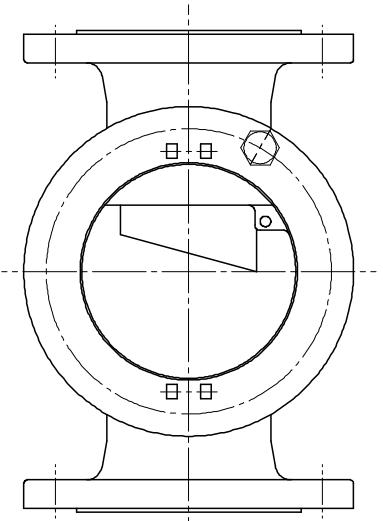
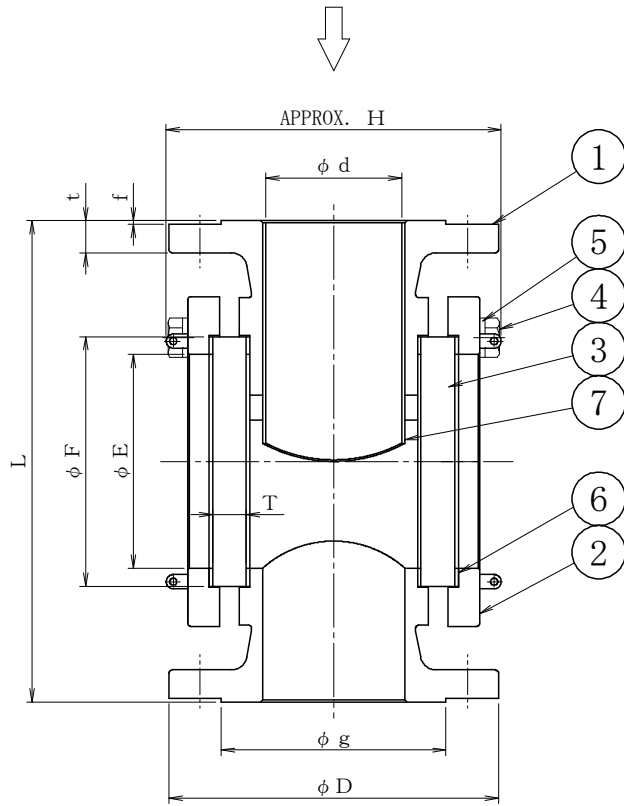

7	NOZZLE	SUS304	1	
6	GASKET	T#9007-G20	4	
5	WASHER	SUS304	SET	
4	BOLT	SUS304	SET	
3	GLASS	TEMPERED GLASS	2	
2	COVER	SCS13A	2	
1	BODY	SCS13A	1	
No	NAME OF PART	MATERIAL	Q.T.Y	REMARKS

NAME 10K NOZZLE TYPE  
FLANGED SIGHT GLASS

FLUID	DESIGN PRESSURE	DESIGN TEMPERATURE	TEST PRESSURE	BODY	
				(HYD)	(AIR)
	1.0 MPaG	150 °C		1.5 MPaG	— MPaG
				SEAT	
				(HYD)	(AIR)
				— MPaG	— MPaG

DRAWING No			MODEL No 10FGL-4-13A	
DATE	A. P	C. K	D. S	D. W
MAY. 12. 2023	TAKAHASHI	TAKAHASHI	MORITA	HORIE

No	DESCRIPTION	DATE	A. P	C. K	D. W
REVISIONS					