

SIZE	R c. d	L	H	H2	H3	d0	l	S	Q' TY
1/4	8	1/4	70	45	57	73	13	30	23
3/8	10	3/8	70	45	57	73	13	30	23
1/2	15	1/2	85	55	73	89	18	40	28
3/4	20	3/4	100	70	93	110	23	52	34
1	25	1	115	80	104	126	30	56	42
1 1/4	32	1 1/4	135	95	125	150	37	68	52
1 1/2	40	1 1/2	150	100	132	159	43	71	58
2	50	2	180	115	153	183	53	82	72

SCREEN

	MESH
	20 MESH
	40 MESH
	60 MESH
	80 MESH
	100 MESH

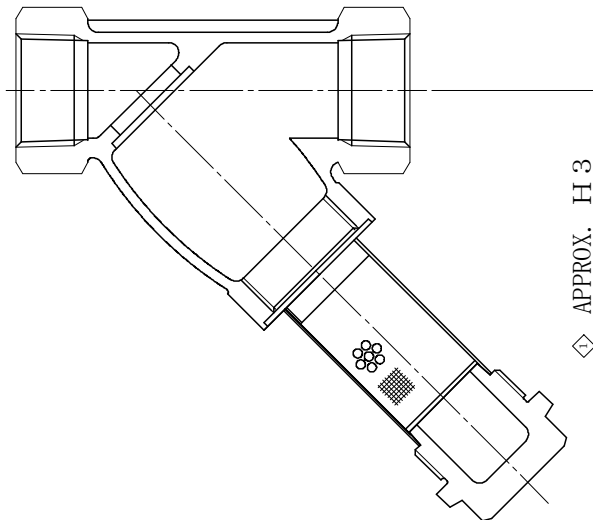
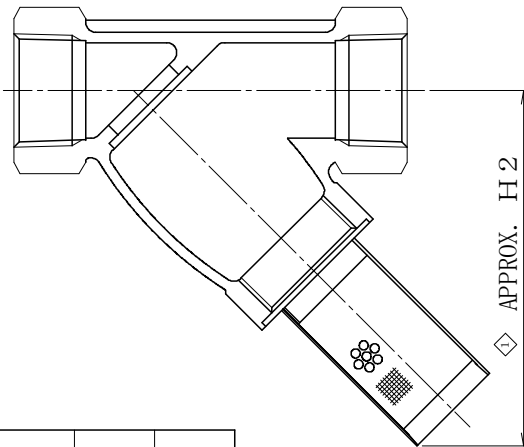

No	NAME OF PART	MATERIAL	Q.T.Y	REMARKS
4	GASKET	T#9007-G20	1	
3	SCREEN	SUS316	1	
2	CAP	SCS14A	1	
1	BODY	SCS14A	1	

NAME 20K
SCREWED Y TYPE STRAINER

FLUID	DESIGN PRESSURE	DESIGN TEMPERATURE	TEST PRESSURE	BODY	SEAT
	2.0 MPaG	150 °C		(HYD) 3.0 MPaG (AIR) MPaG	(HYD) MPaG (AIR) MPaG
				(HYD) MPaG (AIR) MPaG	(HYD) MPaG (AIR) MPaG

DRAWING No _____ MODEL No 20SYL-14A

DATE	A. P	C. K	D. S	D. W
MAY. 29, 2013	MORITA	MORITA	KAIMOTO	HISAKA

No	DESCRIPTION	DATE	A. P	C. K	D. W
◇	Changed the specification	APR. 27, 2020	TAKAHASHI	TAKAHASHI	MORITA

REVISIONS