

10FYP-04

SIZE	d	L	FLANGED								d0	l	H1	W	Q'ty
			D	C	g	f	t	N	h						
50	2	60.5	290	155	120	96	2	16	4	19	37	236	353	R1/2	
65	2 1/2	76.3	320	175	140	116	2	18	4	19	52	245	373	R1/2	
80	3	89.1	320	185	150	126	2	18	8	19	60	305	455	R3/4	
100	4	114.3	400	210	175	151	2	18	8	19	80	345	530	R3/4	
125	5	139.8	450	250	210	182	2	20	8	23	110	391	611	R3/4	
150	6	165.2	480	280	240	212	2	22	8	23	120	430	671	R3/4	
200	8	216.3	580	330	290	262	2	22	12	23	170	512	814	R3/4	
250	10	267.4	680	400	355	324	2	24	12	25	220	617	993	R3/4	

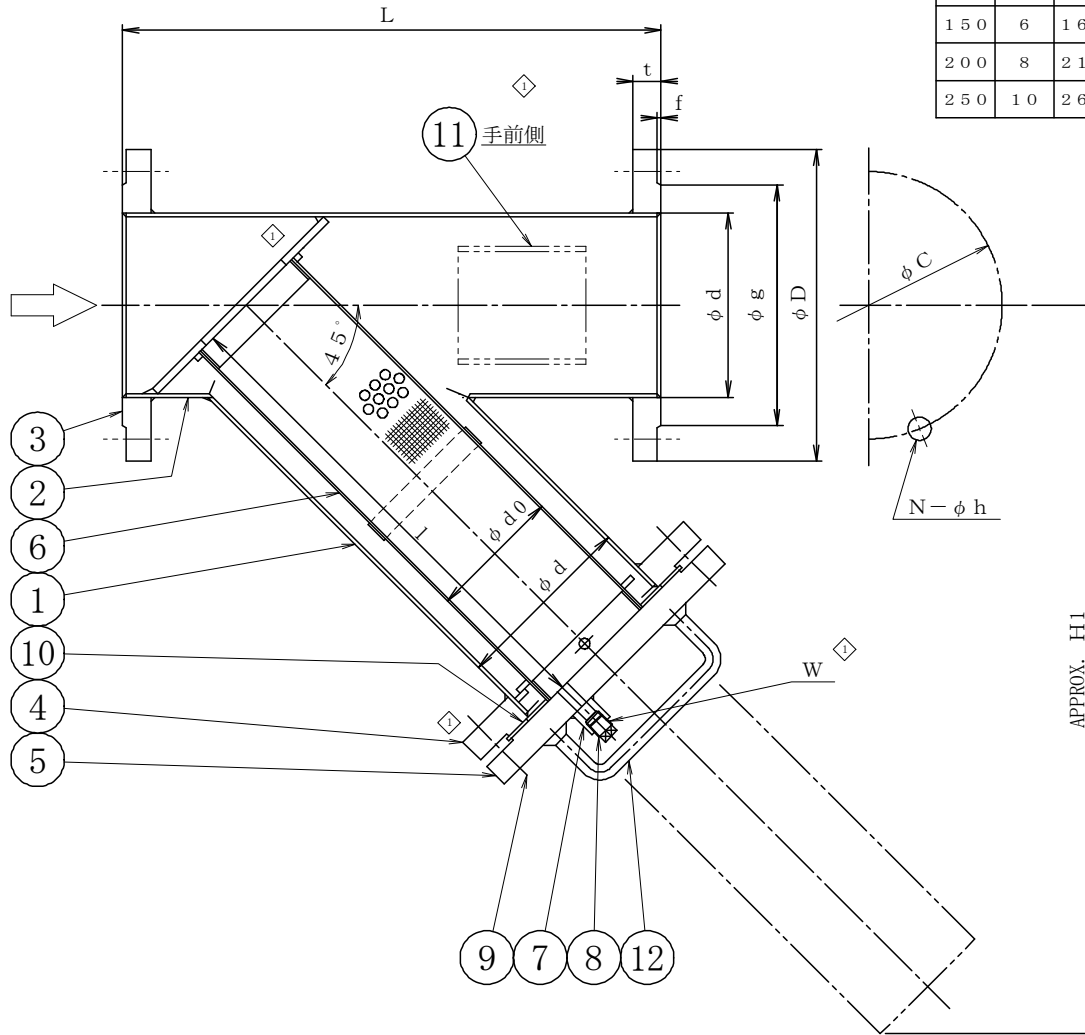

SCREEN

	MESH
	20 MESH
	40 MESH
	60 MESH
	80 MESH
	100 MESH

◇	12	COVER HANDLE	SUS304	2	t25A AND OVER
◇	11	NAME PLATE SEAT	SUS304	1	
◇	10	GASKET	V#N7030N	1	t2.8
◇	9	BOLT NUT(HEX.)	SUS304	SET	
	8	DRAIN PLUG	SUS304	1	
	7	DRAIN BOSS	SUS304	1	
	6	SCREEN	SUS304	1	
◇	5	COVER	SUSF304	1	
◇	4	BODY FLANGE	SUSF304	1	
◇	3	NOZZLE FLANGE	SUSF304	2	
◇	2	NOZZLE PIPE	SUS304TP-A	1	
◇	1	BODY PIPE	SUS304TP-A	1	

No	NAME OF PART	MATERIAL	Q.T.Y	REMARKS
----	--------------	----------	-------	---------

NAME 10K
FLANGED Y TYPE STRAINER

FLUID	DESIGN PRESSURE	DESIGN TEMPERATURE	TEST PRESSURE	BODY	
				(HYD)	(AIR)
	1.0 MPaG	150 °C		1.5 MPaG	MPaG
				SEAT	
				(HYD)	MPaG
				(AIR)	MPaG
				(HYD)	MPaG
				(AIR)	MPaG

DRAWING No		MODEL No 10FYP-04		
DATE	A. P	C. K	D. S	D. W
SEP. 7, 2005	TAKASHIMA	TAKASHIMA	MORITA	KAIMOTO



THREE-M INDUSTRY CO., LTD.

No	DESCRIPTION	DATE	A. P	C. K	D. W
◇	Revised drawing	JAN. 14. 2025	KAMIMAE	KAMIMAE	KONISHI
REVISIONS					