

150FYP-04

| SIZE | d | L | FLANGED | | | | | | | | d0 | l | H1 | W | Q'ty |
|-------|-----|-------|---------|-----|-------|-------|-----|------|----|----|-----|-----|-----|------|------|
| | | | D | C | g | f | t | N | h | | | | | | |
| 2 | 50 | 60.5 | 290 | 152 | 120.6 | 91.9 | 1.6 | 19.1 | 4 | 19 | 37 | 236 | 353 | R1/2 | |
| 2 1/2 | 65 | 76.3 | 320 | 178 | 139.7 | 104.6 | 1.6 | 22.4 | 4 | 19 | 52 | 245 | 373 | R1/2 | |
| 3 | 80 | 89.1 | 320 | 190 | 152.4 | 127.0 | 1.6 | 23.9 | 4 | 19 | 60 | 305 | 455 | R3/4 | |
| 4 | 100 | 114.3 | 400 | 229 | 190.5 | 157.2 | 1.6 | 23.9 | 8 | 19 | 80 | 345 | 530 | R3/4 | |
| 5 | 125 | 139.8 | 450 | 254 | 215.9 | 185.7 | 1.6 | 23.9 | 8 | 22 | 110 | 391 | 611 | R3/4 | |
| 6 | 150 | 165.2 | 480 | 279 | 241.3 | 215.9 | 1.6 | 25.4 | 8 | 22 | 120 | 430 | 671 | R3/4 | |
| 8 | 200 | 216.3 | 580 | 343 | 298.4 | 269.7 | 1.6 | 28.5 | 8 | 22 | 170 | 512 | 814 | R3/4 | |
| 10 | 250 | 267.4 | 680 | 406 | 362.0 | 323.8 | 1.6 | 30.3 | 12 | 26 | 220 | 617 | 993 | R3/4 | |

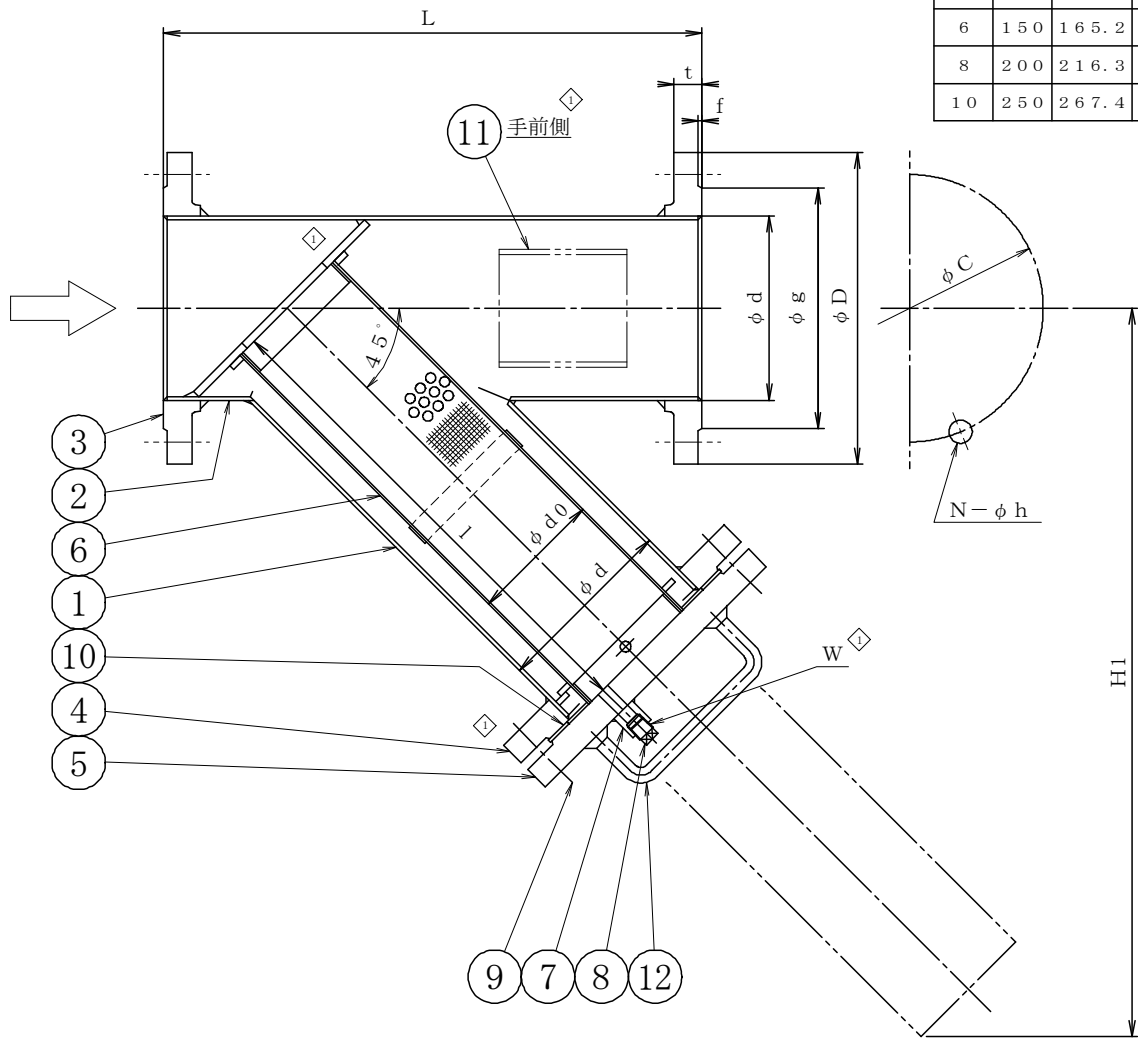

| SCREEN | |
|--------|----------|
| | MESH |
| | 20 MESH |
| | 40 MESH |
| | 60 MESH |
| | 80 MESH |
| | 100 MESH |

| | | | | | |
|---|----|-----------------|------------|-----|---------------|
| ◇ | 12 | COVER HANDLE | SUS304 | 2 | 125A AND OVER |
| ◇ | 11 | NAME PLATE SEAT | SUS304 | 1 | |
| ◇ | 10 | GASKET | V#N7030N | 1 | t2.8 |
| ◇ | 9 | BOLT NUT(HEX.) | SUS304 | SET | |
| | 8 | DRAIN PLUG | SUS304 | 1 | |
| | 7 | DRAIN BOSS | SUS304 | 1 | |
| | 6 | SCREEN | SUS304 | 1 | |
| ◇ | 5 | COVER | SUSF304 | 1 | JIS10K-BLRF |
| ◇ | 4 | BODY FLANGE | SUSF304 | 1 | JIS10K-SOPRF |
| ◇ | 3 | NOZZLE FLANGE | SUSF304 | 2 | |
| ◇ | 2 | NOZZLE PIPE | SUS304TP-A | 1 | |
| ◇ | 1 | BODY PIPE | SUS304TP-A | 1 | |

| No | NAME OF PART | MATERIAL | Q.T.Y | REMARKS |
|----|--------------|----------|-------|---------|
|----|--------------|----------|-------|---------|

NAME CLASS 150
FLANGED Y TYPE STRAINER

| | | | | | |
|--------------------|----------|---------------|------|-------|----------|
| FLUID | | TEST PRESSURE | BODY | (HYD) | 1.5 MPaG |
| | | | | (AIR) | MPaG |
| DESIGN PRESSURE | 1.0 MPaG | | SEAT | (HYD) | MPaG |
| | | | | (AIR) | MPaG |
| DESIGN TEMPERATURE | 150 °C | | | (HYD) | MPaG |
| | | | | (AIR) | MPaG |

DRAWING No _____ MODEL No 150FYP-04

| | | | | |
|--------------|-----------|-----------|--------|---------|
| DATE | A. P | C. K | D. S | D. W |
| SEP. 7, 2005 | TAKASHIMA | TAKASHIMA | MORITA | KAIMOTO |

MM THREE-M INDUSTRY CO., LTD.

| No | DESCRIPTION | DATE | A. P | C. K | D. W |
|----|-----------------|---------------|---------|---------|---------|
| ◇ | Revised drawing | JAN. 14, 2025 | KAMIMAE | KAMIMAE | KONISHI |

REVISIONS