

# 150FYP-SP

SIZE	d	L	FLANGED								d0	l	H1	W	Q'ty
			D	C	g	f	t	N	h						
2	50	60.5	290	152	120.6	91.9	1.6	19.1	4	19	37	236	353	R1/2	
2 1/2	65	76.3	320	178	139.7	104.6	1.6	22.4	4	19	52	245	373	R1/2	
3	80	89.1	320	190	152.4	127.0	1.6	23.9	4	19	60	305	455	R3/4	
4	100	114.3	400	229	190.5	157.2	1.6	23.9	8	19	80	345	530	R3/4	
5	125	139.8	450	254	215.9	185.7	1.6	23.9	8	22	110	391	611	R3/4	
6	150	165.2	480	279	241.3	215.9	1.6	25.4	8	22	120	430	671	R3/4	
8	200	216.3	580	343	298.4	269.7	1.6	28.5	8	22	170	512	814	R3/4	
10	250	267.4	680	406	362.0	323.8	1.6	30.3	12	26	220	617	993	R3/4	

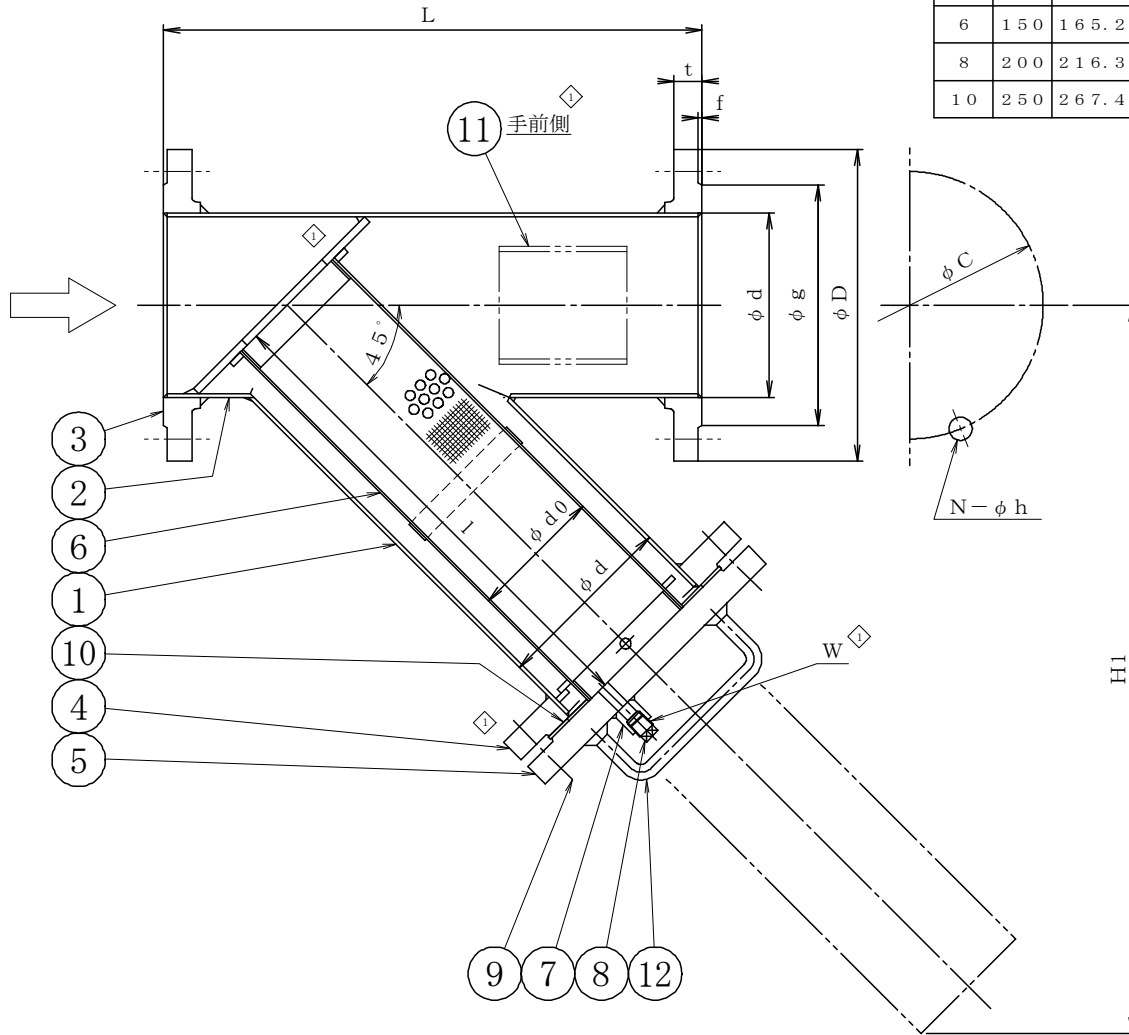

### SCREEN

	MESH
	20 MESH
	40 MESH
	60 MESH
	80 MESH
	100 MESH

### 外面塗装

	錆止め1回塗り(赤錆色)	~60°C(設計温度)
	耐熱錆止め1回塗り(赤錆色)	61~100°C(設計温度)
	錆止め1回塗り+上塗り「シルバー」1回塗り	~60°C(設計温度)
	耐熱錆止め1回塗り+上塗り耐熱「シルバー」1回塗り	61~100°C(設計温度)
	客先仕様通り	

◇	12	COVER HANDLE	SS400	2	125A AND OVER
◇	11	NAME PLATE SEAT	SS400	1	
◇	10	GASKET	T#1995	1	t3.0
◇	9	BOLT NUT(HEX.)	SS400	SET	UNI-CHROME
	8	DRAIN PLUG	S25C	1	
	7	DRAIN BOSS	S25C	1	
	6	SCREEN	SUS304	1	
◇	5	COVER	SS400	1	JIS10K-BLRF
◇	4	BODY FLANGE	SS400	1	JIS10K-SOPRF
◇	3	NOZZLE FLANGE	SFVC2A	2	
◇	2	NOZZLE PIPE	SGP-E	1	
◇	1	BODY PIPE	SGP-E	1	

No	NAME OF PART	MATERIAL	Q.T.Y	REMARKS
----	--------------	----------	-------	---------

NAME CLASS 150  
FLANGED Y TYPE STRAINER

FLUID	DESIGN PRESSURE	DESIGN TEMPERATURE	TEST PRESSURE	BODY	
				(HYD)	(AIR)
	1.0 MPaG	100 °C		1.5 MPaG	MPaG
				SEAT	
				(HYD)	MPaG
				(AIR)	MPaG
				(HYD)	MPaG
				(AIR)	MPaG

DRAWING No \_\_\_\_\_ MODEL No 150FYP-SP

DATE	A. P	C. K	D. S	D. W
SEP. 12, 2005	TAKASHIMA	TAKASHIMA	MORITA	KAIMOTO

**MM** THREE-M INDUSTRY CO., LTD.

No	DESCRIPTION	DATE	A. P	C. K	D. W
◇	Revised drawing	JAN. 14, 2025	KAMIMAE	KAMIMAE	KONISHI
REVISIONS					