

# 20FYP-04

SIZE	d	L	FLANGED								d0	l	H1	W	Q'ty
			D	C	g	f	t	N	h						
50	2	60.5	290	155	120	96	2	18	8	19	37	236	353	R1/2	
65	2 1/2	76.3	320	175	140	116	2	20	8	19	52	245	373	R1/2	
80	3	89.1	320	200	160	132	2	22	8	23	60	305	455	R3/4	
100	4	114.3	400	225	185	160	2	24	8	23	80	345	530	R3/4	
125	5	139.8	450	270	225	195	2	26	8	25	110	391	611	R3/4	
150	6	165.2	480	305	260	230	2	28	12	25	120	430	671	R3/4	
200	8	216.3	580	350	305	275	2	30	12	25	170	512	814	R3/4	
250	10	267.4	680	430	380	345	2	34	12	27	220	617	993	R3/4	

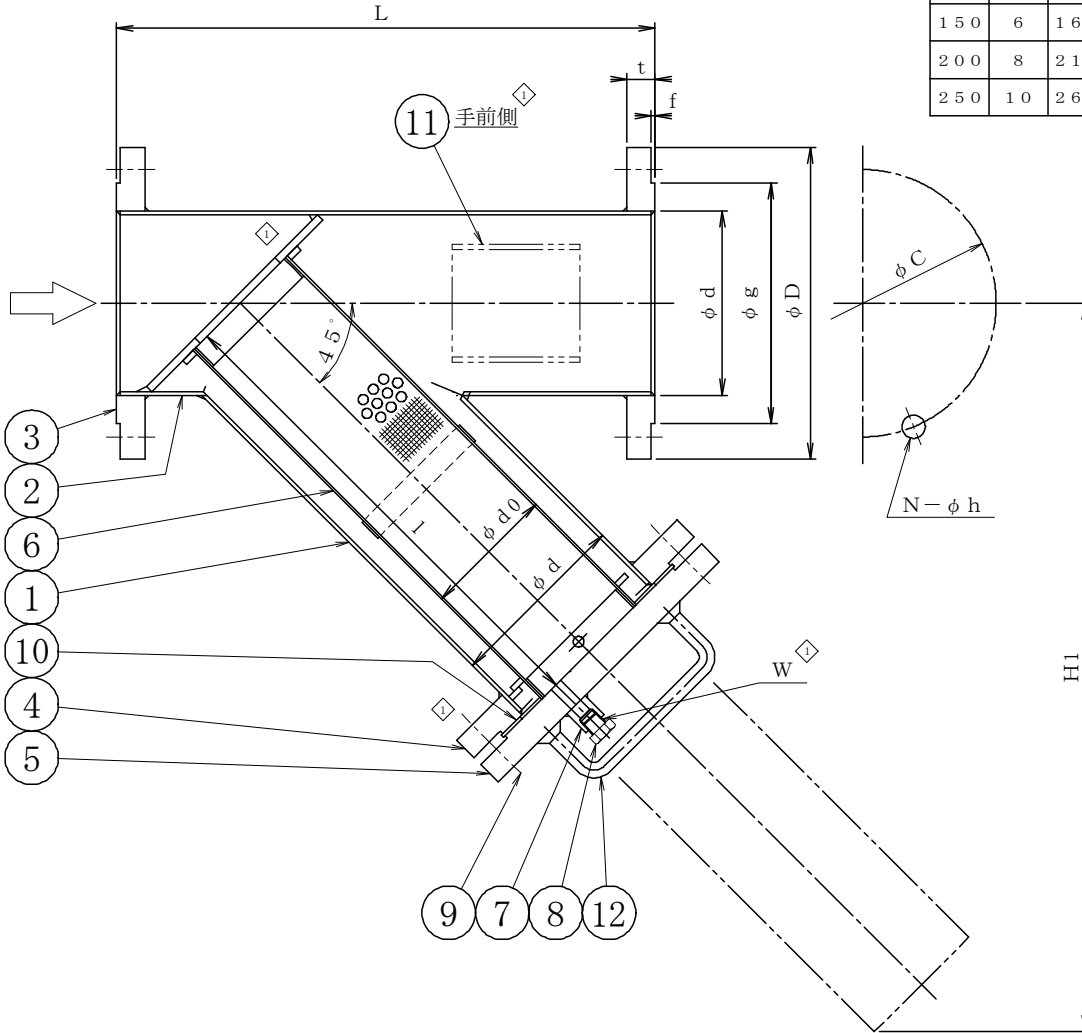

SCREEN	
	MESH
	20 MESH
	40 MESH
	60 MESH
	80 MESH
	100 MESH

◇	12	COVER HANDLE	SUS304	2	125A AND OVER
◇	11	NAME PLATE SEAT	SUS304	1	
◇	10	GASKET	T#11133	1	t3.0
◇	9	STUD BOLT NUT	SUS304	SET	
	8	DRAIN PLUG	SUS304	1	
	7	DRAIN BOSS	SUS304	1	
	6	SCREEN	SUS304	1	
◇	5	COVER	SUSF304	1	
◇	4	BODY FLANGE	SUSF304	1	
◇	3	NOZZLE FLANGE	SUSF304	2	
◇	2	NOZZLE PIPE	SUS304TP-A	1	
◇	1	BODY PIPE	SUS304TP-A	1	

No	NAME OF PART	MATERIAL	Q.T.Y	REMARKS
----	--------------	----------	-------	---------

NAME 20K  
FLANGED Y TYPE STRAINER

FLUID	DESIGN PRESSURE	DESIGN TEMPERATURE	TEST PRESSURE	BODY	
				(HYD)	(AIR)
	2.0 MPaG	150 °C		3.0 MPaG	MPaG
				SEAT	
				(HYD)	MPaG
				(AIR)	MPaG
				(HYD)	MPaG
				(AIR)	MPaG

DRAWING No			MODEL No 20FYP-04	
DATE	A. P	C. K	D. S	D. W
SEP. 12, 2005	TAKASHIMA	TAKASHIMA	MORITA	KAIMOTO

**MM** THREE-M INDUSTRY CO., LTD.

No	DESCRIPTION	DATE	A. P	C. K	D. W
◇	Revised drawing	JAN. 14, 2025	KAMIMAE	KAMIMAE	KONISHI
REVISIONS					