

# 20FYP-06

SIZE	d	L	FLANGED								d0	l	H1	W	Q'ty
			D	C	g	f	t	N	h						
50	2	60.5	290	155	120	96	2	18	8	19	37	236	353	R1/2	
65	2 1/2	76.3	320	175	140	116	2	20	8	19	52	245	373	R1/2	
80	3	89.1	320	200	160	132	2	22	8	23	60	305	455	R3/4	
100	4	114.3	400	225	185	160	2	24	8	23	80	345	530	R3/4	
125	5	139.8	450	270	225	195	2	26	8	25	110	391	611	R3/4	
150	6	165.2	480	305	260	230	2	28	12	25	120	430	671	R3/4	
200	8	216.3	580	350	305	275	2	30	12	25	170	512	814	R3/4	
250	10	267.4	680	430	380	345	2	34	12	27	220	617	993	R3/4	

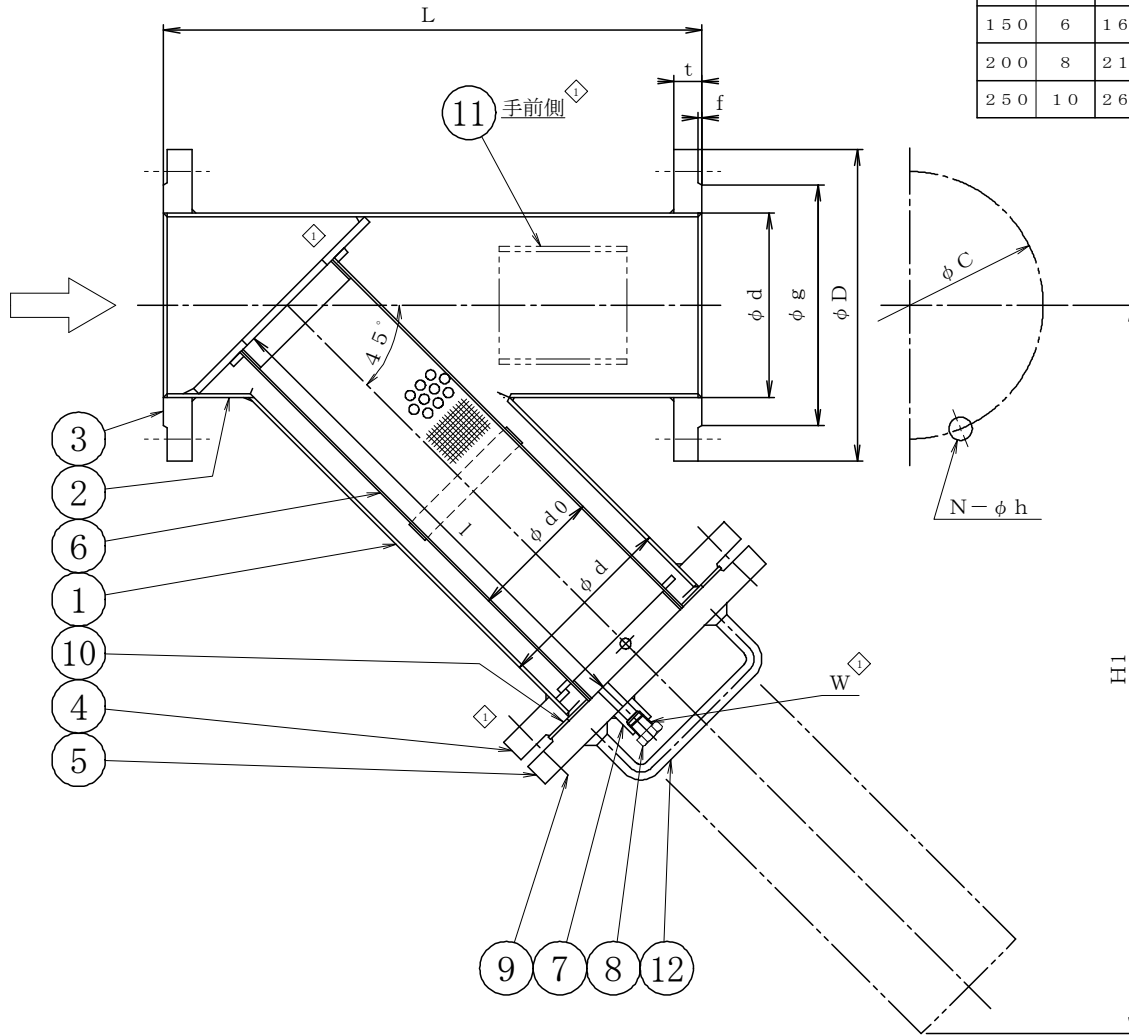

### SCREEN

SCREEN	MESH
	20 MESH
	40 MESH
	60 MESH
	80 MESH
	100 MESH

12	COVER HANDLE	SUS304	2	125A AND OVRE
11	NAME PLATE SEAT	SUS304	1	
10	GASKET	T#11133	1	t3.0
9	STUD BOLT NUT	SUS304	SET	
8	DRAIN PLUG	SUS316	1	
7	DRAIN BOSS	SUS316	1	
6	SCREEN	SUS316	1	
5	COVER	SUSF316	1	
4	BODY FLANGE	SUSF316	1	
3	NOZZLE FLANGE	SUSF316	2	
2	NOZZLE PIPE	SUS316TP-A	1	
1	BODY PIPE	SUS316TP-A	1	

No	NAME OF PART	MATERIAL	Q.T.Y	REMARKS
----	--------------	----------	-------	---------

NAME 20K  
FLANGED Y TYPE STRAINER

FLUID	DESIGN PRESSURE	DESIGN TEMPERATURE	TEST PRESSURE	BODY	SEAT
	2.0 MPaG	150 °C		(HYD) 3.0 MPaG (AIR) MPaG	(HYD) MPaG (AIR) MPaG
				(HYD) MPaG (AIR) MPaG	(HYD) MPaG (AIR) MPaG

DRAWING No MODEL No 20FYP-06

DATE	A. P	C. K	D. S	D. W
SEP. 12, 2005	TAKASHIMA	TAKASHIMA	MORITA	KAIMOTO

**MM** THREE-M INDUSTRY CO., LTD.

No	DESCRIPTION	DATE	A. P	C. K	D. W
1	Revised drawing	JAN. 14, 2025	KAMIMAE	KAMIMAE	KONISHI

REVISIONS