

300FYP-04

SIZE	d	L	FLANGED								d0	l	H1	W	Q'ty
			D	C	g	f	t	N	h						
2	50	60.5	290	165	127.0	91.9	1.6	22.4	8	19	37	236	353	R1/2	
2 1/2	65	76.3	320	190	149.4	104.6	1.6	25.4	8	22	52	245	373	R1/2	
3	80	89.1	320	210	168.1	127.0	1.6	28.5	8	22	60	305	455	R3/4	
4	100	114.3	400	254	200.2	157.2	1.6	31.8	8	22	80	345	530	R3/4	
5	125	139.8	450	279	235.0	185.7	1.6	35.1	8	22	110	391	611	R3/4	
6	150	165.2	480	318	269.7	215.9	1.6	36.6	12	22	120	430	671	R3/4	
8	200	216.3	580	381	330.2	269.7	1.6	41.2	12	26	170	512	814	R3/4	
10	250	267.4	680	444	387.4	323.8	1.6	47.8	16	29	220	617	993	R3/4	

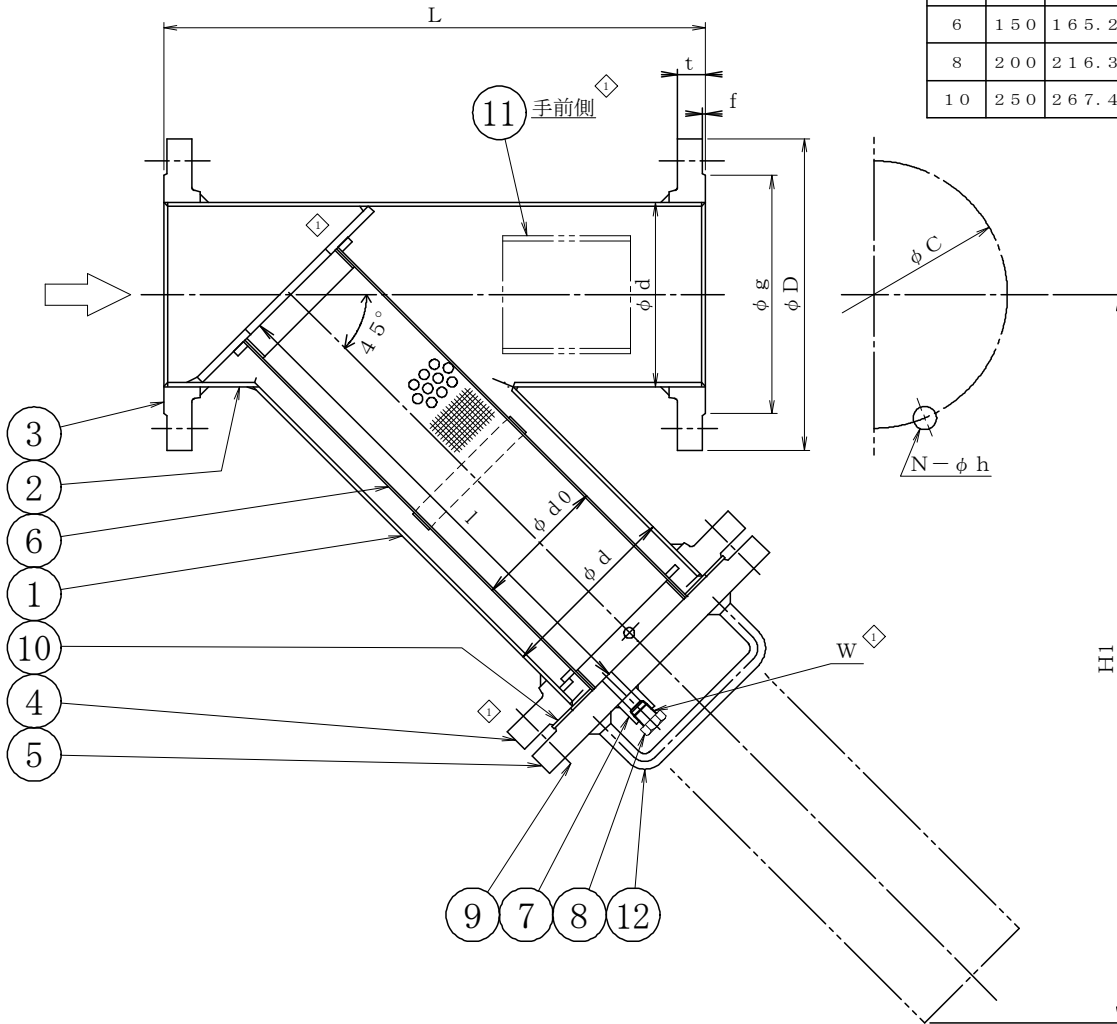

SCREEN	
	MESH
	20 MESH
	40 MESH
	60 MESH
	80 MESH
	100 MESH

12	COVER HANDLE	SUS304	1	125A AND OVER
11	NAME PLATE SEAT	SUS304	1	
10	GASKET	T#11133	1	t3.0
9	STUD BOLT NUT	SUS304	SET	
8	DRAIN PLUG	SUS304	1	
7	DRAIN BOSS	SUS304	1	
6	SCREEN	SUS304	1	
5	COVER	SUSF304	1	
4	BODY FLANGE	SUSF304	1	
3	NOZZLE FLANGE	SUSF304	2	
2	NOZZLE PIPE	SUS304TP-A	1	
1	BODY PIPE	SUS304TP-A	1	

No	NAME OF PART	MATERIAL	Q.T.Y	REMARKS
----	--------------	----------	-------	---------

NAME CLASS 300
FLANGED Y TYPE STRAINER

FLUID		TEST PRESSURE	BODY	(HYD)	3.0 MPaG
				(AIR)	MPaG
DESIGN PRESSURE	2.0 MPaG		SEAT	(HYD)	MPaG
				(AIR)	MPaG
DESIGN TEMPERATURE	150 °C			(HYD)	MPaG
				(AIR)	MPaG

DRAWING No _____ MODEL No 300FYP-04

DATE	A. P	C. K	D. S	D. W
SEP. 12, 2005	TAKASHIMA	TAKASHIMA	MORITA	KAIMOTO

MM THREE-M INDUSTRY CO., LTD.

No	DESCRIPTION	DATE	A. P	C. K	D. W
1	Revised drawing	JAN. 14, 2025	KAMIMAE	KAMIMAE	KONISHI

REVISIONS